



## WOODLOC® 5G FLOAT-IN INSTALLATION INSTRUCTIONS

---

Applicable to:

Kährs 13mm Canvas Collection 1/2"

### **PROTECT YOUR INVESTMENT!**

Maintain your warranty:  
Only use Kährs branded  
underlayments,  
moldings, cleaning  
supplies, and  
accessories.



## JOBSITE

### Underlayments

#### • Kährs Combo-System Underlayment

Combo Foam Underlayment System with Overlap: The width of a row of Combo-System Underlayment is comprised of 40" of underlayment plus an 8" overlap flap. The overlap flap guards the flooring from moisture at the seams, where the rows of underlayment are laid side by side. The overlap flap has a peel and stick strip to aid the installation process.

1. Layout 1st row of underlayment (logo side down, blue side up) with the overlap flap facing the starting wall. Allow the underlayment to wrap up the wall, on the ends, approx. 2".
2. Reach under and grab the overlap flap and pull it up so it lies against the starting wall. Trim this overlap flap back to leave approx. 2" of plastic up the wall. (Use this cut off section to repair damage in the underlayment as needed\*, see note below).
3. Lay 2nd row of underlayment flush to first. Make sure the overlap flap is next to 1st row, and the ends wrap up the walls. (If flooring installation has already begun, make sure to stop the flooring approx. 8 inches from the side of the underlayment to allow for the installation of the overlap flap.)
4. Again, reach under and grab the overlap flap. Pull the flap up and fold it back to expose the peel and stick strip. Remove the white protective cover from the adhesive strip. Lay overlap flap across the 1st row of underlayment and press into place.
5. Continue this procedure row by row until the entire floor area is covered.

\*Note: When connecting a new roll of underlayment to the end of the roll you are working on, or for repairing any tears or cuts in the underlayment; overlay the butt joints or the damaged area with a spare piece of overlap plastic. This spare piece should overlay by approx. 8". Hold the spare piece in place with tape. Do NOT overlap underlayment. Overlap flap only.

Cover the entire floor area and run the underlayment up the perimeter walls approximately 2". This provides a secure enclosure for the flooring. After the floor is installed and before the installation of the baseboards, the excess underlayment should be trimmed to the height of the floor surface using a fine trimming blade. The use of the Combo-System Underlayment is also approved for Radiant Heat applications.

#### • Kährs QuietStride

QuietStride can be installed three different ways as a Karella underlayment.

1. Float-in Installations: First install 6 mil polyethylene plastic loose-laid, seams overlapped 8". Run plastic up the wall 2" (trim excess after installation, before installing trim). Loose-lay QuietStride on top of plastic, wall to wall, and butt all seams together (taping seams preferred). Use of QuietStride with polyethylene plastic is approved for float-in Radiant Heat applications.
2. Direct Glue-Down: Install QuietStride wall to wall, butt all seams together (do not tape seams), directly adhering to subfloor with pressure sensitive adhesive or a premium multi-purpose adhesive. Fully adhere Kährs flooring to underlayment using approved adhesive and trowel (see Glue-Down Installation for details). Note: an approved concrete sealer must be used if calcium chloride test exceeds 3lbs. for Kährs Moisture Protection Warranty to apply.
3. Direct Glue-Down over "float-in" underlayment: First install 6 mil polyethylene plastic loose-laid, seams overlapped 8". Run plastic up wall 2" (trim excess after installation, before installing trim). Loose-lay QuietStride on top of plastic, wall to wall, butt all seams together (do not tape seams). Fully adhere Kährs flooring to underlayment using approved adhesive and trowel (see Glue-Down Installation for details). Note: a concrete sealer must be used if calcium chloride test exceeds 3lbs. for Kährs Moisture Protection Warranty to apply.

## JOBSITE

### Underlayments

**Specialty adhesives (pressure sensitive)** have been developed for adhering QuietStride underlayment directly to the subfloor for use in “double-stick” installations. The adhesive is a quick, inexpensive technique for affixing QuietStride Underlayment to the subfloor, then gluing the Kährs flooring to the QuietStride Underlayment with one of the adhesive manufacturer’s approved wood flooring adhesives. The adhesive manufacturer can also recommend the specialty adhesive that is best for this application.

#### • Kährs Eco+ Underlayment with Vapor Bloc

Kährs Eco+ underlayment can be installed utilizing the floating or nail-down installation method with the film side up, fabric side down. NOTE: Nail-down installation method compromises the vapor barrier. Do NOT glue down Eco+ with Vapor Bloc. Eco+ without Vapor Bloc film is available for glue down installation. For more information contact Kährs customer service at 800-800-5247.

1. Be sure the sub-floor is clean and dry.
2. Roll out one section of the Eco+ with Vapor Bloc parallel to the wall and in the same direction as you plan to install the wood flooring. The product will roll out with the Vapor Bloc film up and the foam side down to the sub-floor.
3. Next install the wooden planks atop the underlayment in accordance with the specific installation instructions for that product. Be sure that you can still see the edge of the underlayment so that you can properly line up the next roll.
4. Install the next section of underlayment, butting the foam underlayment seams together. Remove the release film and press the overlapping Vapor Bloc film into the pre-applied adhesive, making certain the film is securely bonded to the adjacent section of underlayment. Repeat the above steps until the installation is complete.
5. Be sure to allow appropriate expansion gaps at the perimeter and any vertical fixed objects as specified in the installation instructions.

**Important: Kährs does not guarantee the performance of any non-Kährs branded underlayment.**

## LAYOUT

### Required Expansion

Purpose: To ensure proper expansion space around all walls, doors, and obstructions.

#### Required Expansion

- Rules:
- 1) Kährs requires 1/16" of expansion space for every 3' of Connected Area width or 9' of connected area length (whichever is greater). This expansion space must be left around all walls, doors and obstructions. Minimum expansion requirement is 1/2".
  - 2) No connected flooring can span greater than 40' in width by 120' in length for products with 2G or 80' in width by 160' in length for 5G
- Notes:
- 1) Connected area is defined as all areas connected without a break. If Room A and Room B both are to have flooring installed and are directly connected, or connected by a hallway, with-out a t-molding, the connected area is the width of both Room A and Room B, and the hall way (if applicable). Obstructions can include cabinets, islands, and the wall opposite the starting wall in the same room, if the flooring continues to another room without a break. Multiple calculations may need to be made to best determine the amount cut from the starting row.
  - 2) The direction of the flooring must be determined prior to calculating the required expansion space. The Connected Area width is parallel to the board width. The connected area length is parallel to the board length.

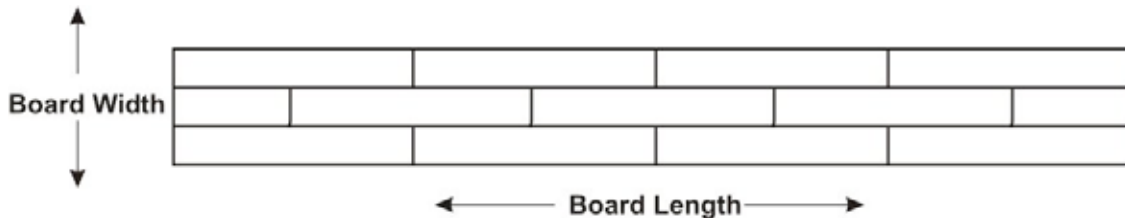

Required Expansion Reference Chart			
Connected Area Width	Required Expansion Space*	Connected Area Length	Required Expansion Space*
Up to 24'	1/2"	Up to 72'	1/2"
24'-40'	3/4"	72' to 120'	3/4"
NOTE: Woodloc® 5G Only 40' - 80'	3/4" - 1 5/8"	120' to 160'	1 1/8"

\* Determine the required expansion space for both width and length, then use the larger of the 2 on all sides, and around all obstructions.

## TOOLS & TECHNIQUES

### Important Installation Notes

Please see our website - [www.kahrs.com](http://www.kahrs.com) for Kährs Floor Care Guide and Lifetime Guarantee.

#### **Installation:**

##### **Floating:**

Maximum room dimensions for a 2G floating floor are 40ft. across the boards or 120 ft. lengthwise.

Maximum room dimensions for a 5G floating floor are 80ft. across the boards and 160ft lengthwise.

Floors exceeding either of these dimensions require use of "T-Molding."

**A minimum of one butt seam is required in every row, regardless of width (e.g. hallways).**

Never attach any permanent object through the flooring, affixing it to the subfloor. A float-in floor must be free to expand and contract in all directions.

Kährs Flooring is approved for installations in ½ bathrooms only (no bathrooms including showers or bath tubs)

#### **Expansion in Large Areas:**

You may be able to attain the necessary added expansion by trimming the wallboard (i.e. sheetrock) or raising baseboards before installing floor. This will allow the floor to expand underneath the wall. For complete information please refer to Required Expansion Reference Charts on pages 8 and 9 in the Layout section of this Guide. A Kährs floor requires 1/16" expansion for every 3' across width and 1/16" expansion for every 9' along length. For example, a 27' x 27' space requires an expansion gap of 9/16" around the edge of the flooring.

#### **Adhesive Tape on Kährs Floors:**

**The use of adhesive tape on any Kährs floor for any reason (i.e. to fasten temporary protection) is not recommended and is not covered in our warranty.**

#### **Additional Finishing Coating:**

For additional wear protection, a waterborne urethane finish is compatible with Karelia factory finishes. Contact Arboritec (1-877-416-5972) or Bona Kemi USA, Inc. (1-800-574-4674) for recommended products, application and warranty information. Follow manufacturer's instructions for recoating a prefinished wood floor. Karelia does not guarantee the performance and/or durability of these products.

## TOOLS & TECHNIQUES

### Float-In Installation for Woodloc® 5G

#### Notes:

- For subfloor and environmental specifications and requirements, see Jobsite / Subfloor Preparation section. Floating installation requires the use of Kährs Approved Underlayment Systems. Refer to Underlayment section of this Guide.
- Kährs flooring is covered by a Limited Lifetime Warranty. However, Warranty coverage may be lost due to failure to strictly follow all installation instructions and recommendations or the use of improper materials or tools. **READ ALL INSTRUCTIONS CAREFULLY.**

#### IMPORTANT!

- **Do not open packages until ready to begin installation!** Inspect boards as you go. Kährs flooring is sealed at the factory with a 7% moisture content. Opening cartons to acclimate the flooring (as with some solid strip flooring) could result in a difficult installation.
- As an installer, it is your responsibility to be aware of the grade, Relative Humidity of the room, and moisture content of the subfloor. You should check that each plank is free of damage or manufacturing defects. Any unusable boards should be set aside for later replacement.

#### Step 1

Start in corner and lay first board with tongue side toward walls (Fig 1). Proper expansion space can be achieved by pulling floor away from wall once first three rows have been installed (reference Step 6). For proper expansion refer to calculation worksheet.

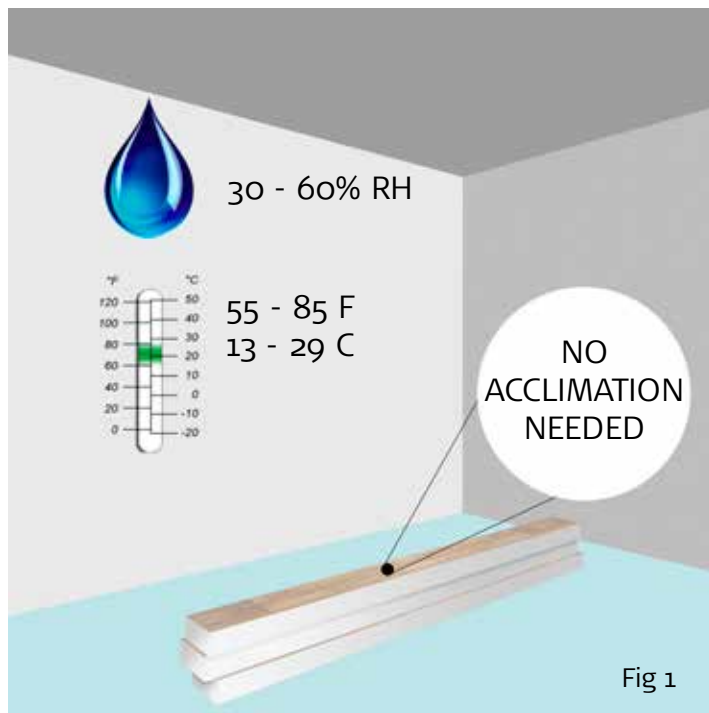

## TOOLS & TECHNIQUES

### Float-In Installation for Woodloc® 5G

#### Step 2

Kährs Woodloc 5G employs a locking pin (Fig. 1, 2) to engage short end of boards. Hold second board against first board at approximately a 20° - 30° angle. Lay second board flat. Once in place, press firmly until an audible click is heard. This will ensure the boards are locked together.

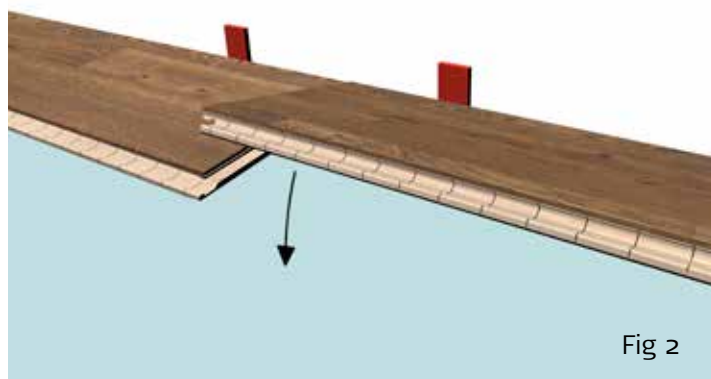
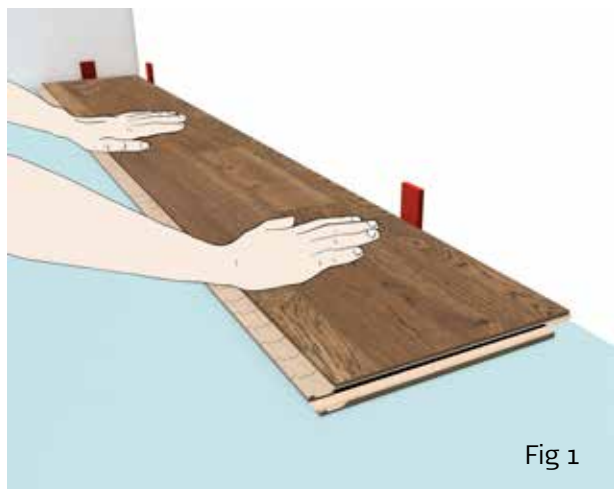

#### Step 3

Once the complete row is installed as described above, the cut off piece at the end of the row can be used as a starter board for the next row providing joints in the adjacent row are staggered a minimum of 25% of the length of the board.

Example: 8' board = 24", 6' board = 18", 4' board 12". Starter boards should be a minimum of 12". (See Fig 3) Butt seam must be placed in each row regard-less of width, e.g. hallways.

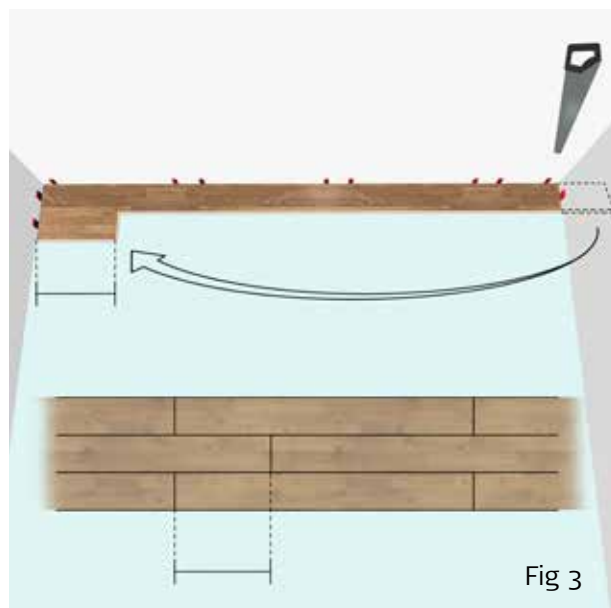

## TOOLS & TECHNIQUES

### Float-In Installation for Woodloc® 5G

#### Step 4

The boards must be inserted into the long joint first at approximately a 20° to 30° angle and then moved flush with the short joint of the previously installed board. Once the board is firmly placed against the short joint of the existing board, tap in the long joint with a knocking block to ensure that it is fully engaged, and press it into place. It is important to press down on the board until you hear the audible 'click'. (Figs 4, 5, 6, 7, 8, 9, 10, 11) Continue installing the boards in the same manner paying attention to the end joint staggers.

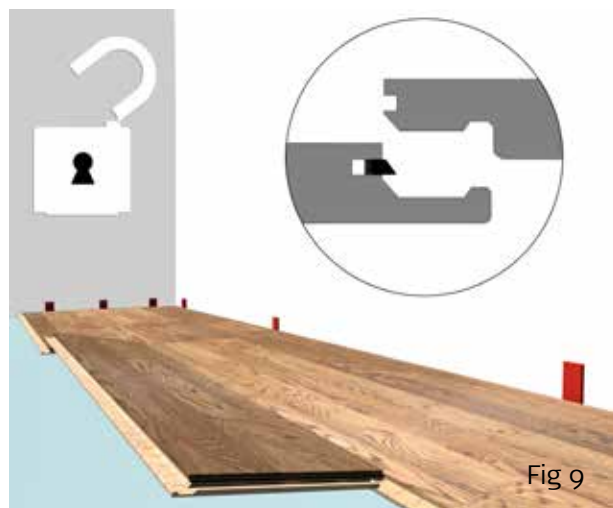
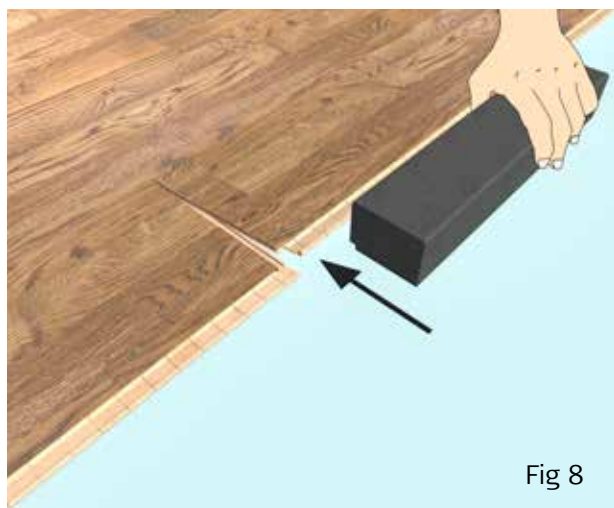
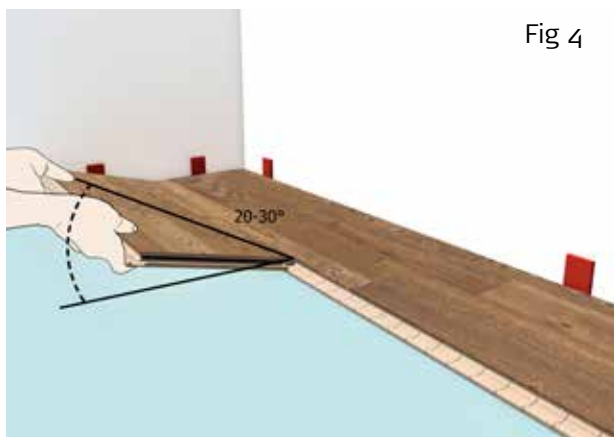



## TOOLS & TECHNIQUES

### Float-In Installation for Woodloc® 5G

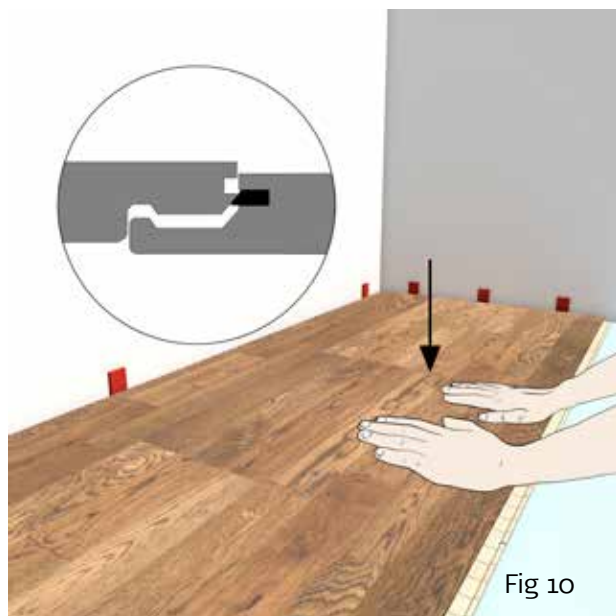

Fig 10

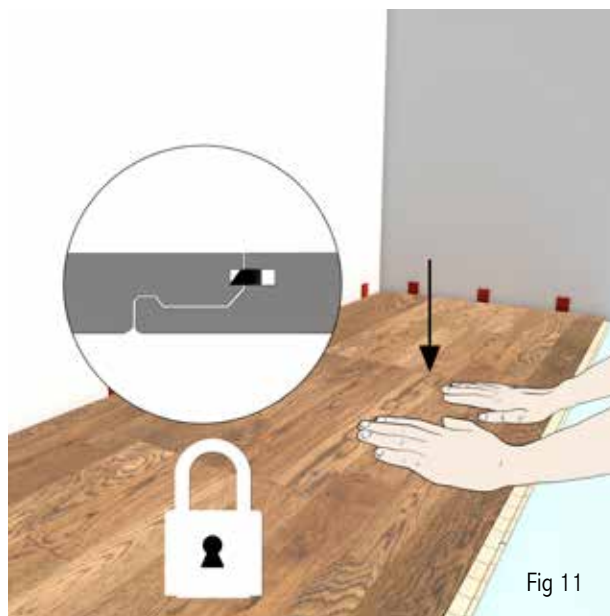

Fig 11

#### Step 5

When three rows have been laid, pull floor away from starting wall until there is proper amount of expansion space. Place expansion shims between floor and wall to maintain this space, as shown in Fig. 1-5, 9-11), then continue installation as described.

#### Step 6

If first (or last) row must be cut to match crooked wall, first disengage row of boards adjacent to crooked wall by gripping long side and pulling upward while simultaneously giving long joint a light tap along entire length (Fig. 12). Now trace shape of wall onto first/last row boards, making sure space is allowed for expansion. See Fig. 13 at right. Saw to shape.

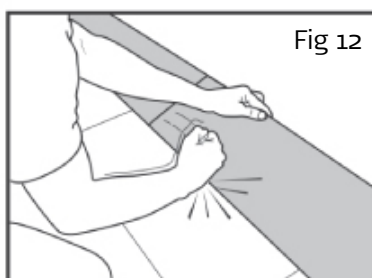

Fig 12

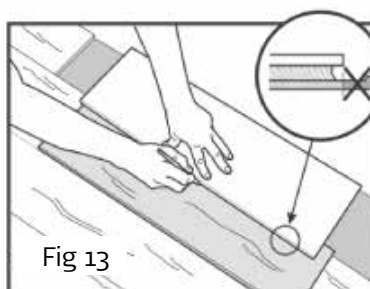

Fig 13

#### Step 7

After sawing row to shape, engage and lock all end joint locking pins and lift entire row and reinstall to adjacent row (Fig. 14). Slide rows back into position against wall. Place expansion shims between floor and wall.

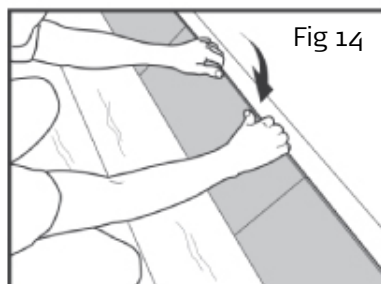

Fig 14

## TOOLS & TECHNIQUES

### Float-In Installation for Woodloc® 5G

#### Step 8

If doorjamb (or similar) needs to be cut, use piece of board and piece of Combo Underlayment to obtain correct height (Fig. 15). If new board needs to be tapped into place, be sure to protect edges with scrap of wood before tapping with handblock.

If boards cannot be easily angled under door frame or similar, cut away locking edge as shown in Fig. 16. Then apply Landobond adhesive and install board as shown in Fig. 17.

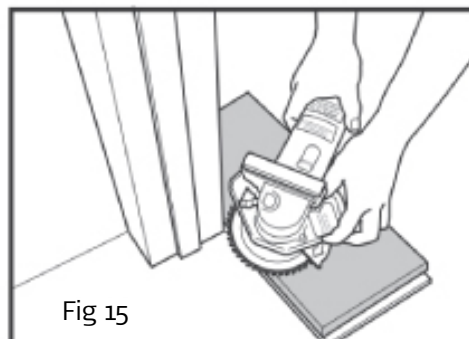

Fig 15

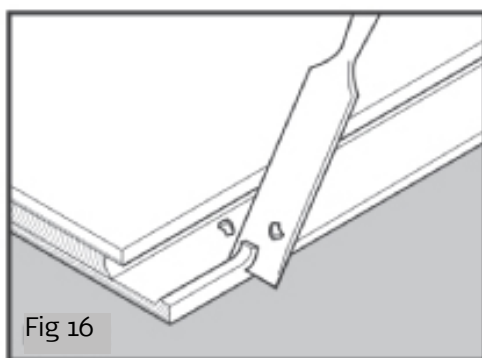

Fig 16

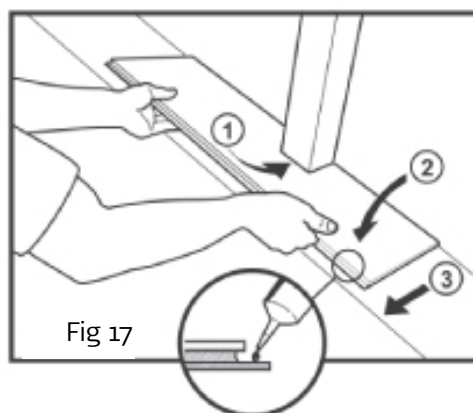
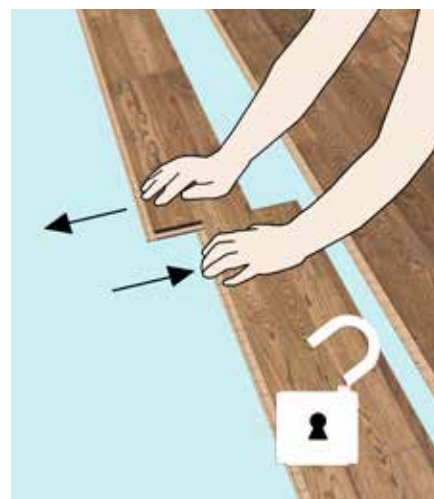

Fig 17

#### Disengaging Boards

Boards can be laid from all directions if necessary. Woodloc® 5S/5G dismantles easily (see Fig. 14). This enables easier planning for difficult installation areas. To disengage locked boards, first detach entire row and place on flat surface. Using Kährs Woodloc Handblock, tap on exposed groove or tongue until boards unlock (Fig. 14).



## TOOLS & TECHNIQUES

### Float-In Installation for Woodloc® 5G

#### **After Installation**

Clean floor using dry dust mop or damp (lightly misted or well rung out) mop or cloth. Regularly use Kährs Wood Floor Cleaner for best results. Do not use oil soap or water-emulsion, self polishing waxes. NEVER wet mop floor. Place Peel & Stick Floor Protectors on furniture legs to prevent damage. See Kährs Floor Care Guide & Lifetime Guarantee for full details (available at [www.kahrs.com](http://www.kahrs.com)). For prefinished oiled floors, please refer to Natural Oiled Floors Maintenance and Renovation Procedures at [www.kahrs.com](http://www.kahrs.com)

#### **Maintenance**

Clean floor using dry dust mop or damp (lightly misted or well rung out) mop or cloth. Regularly use Kährs Wood Floor Cleaner for best results. Do not use oil soap or water-emulsion, self polishing waxes. Never wet mop floor. Place Peel & Stick Floor Protectors on furniture legs to prevent damage. See Kährs Floor Care Guide & Lifetime Guarantee for full details (available at [www.kahrs.com](http://www.kahrs.com)).

**NOTE: Oiled floors must be oiled with Kährs Satin Oil (710553) after installation and prior to use.**

## FOLLOW UP

### Recoating your Kährs Floor

Kährs floors can be renewed without removing the factory finish. As a floor ages, normal wear and tear will cause a floor to lose its luster. This is natural - it happens to all wood floors. To renew the luster and extend the wear layer of the Kährs floor, recoat with water based urethane coating.

Recoating should be done when necessary. Don't wait until the finish has worn down. Call your professional flooring contractor for recommendations as soon as you see a wear pattern developing.

#### **Additional Finishing Coating:**

For additional wear protection, a waterborne urethane finish is compatible with Kährs factory finishes. Contact Arboritec (1-877-416-5972) or Bona Kemi USA, Inc. (1-800-574-4674) for recommended products, application and warranty information. Follow manufacturer's instructions for recoating a prefinished wood floor. Kährs International, Inc. does not guarantee the performance and/or durability of these products.



Kährs  
940 Centre Circle Suite 1000  
Altamonte Springs, FL 32714  
Tel: 1.800.800.5247 Fax: 407.260.9933  
info@kahrs.com www.kahrs.com